

EC Jet Fan

Cleaner air for ventilation car parks

The Jetfan is the ideal solution for increased safety in underground car parks and underpasses. Choose the ultimate system for safer and more aesthetic underground constructions

- The Jetfan can be used for partial smoke extraction or ventilation.
- The flexible positioning of the Jetfan makes sure there are no areas where air does not circulate.
- The Jetfan makes expensive, large-scale duct systems unnecessary.
- Intake air fans will not be necessary if there is a free intake section for outside air.

Safe CO extraction solutions for car park applications

EC Jet Fans can be used in single or multi-level carpark applications where precise control of carbon monoxide is important. EC Jet fans can reduce installation costs and provide an energy saving solution based on simple demand controls.

Benefits of the EC Jet Fan

- Well trusted across the European market
- Variable speed, Variable thrust
- Energy saving EC
- Speed controllable via 0-10V analogue input signal
- Low profile design
- Manufactured from galvanised steel
- German technology based on an airfoil impeller optimised for low noise and highest efficiency

EC Jet Fan

- Centrifugal Smoke Extract Induction Jetfan suitable for smoke extraction in the case of fire up to max. 300 °C – 120 minutes, tested to DIN EN 12101-3 and CE certified.
- Thrust up to 50 N

Smoke Flow Simulation for perfect planning

We will assist you in the detailed planning and dimensioning of car park ventilation equipment, by means of a smoke flow simulation using computational fluid dynamics (CFD).

With the help of CFD, the ideal smoke extraction and ventilation system – including the number and positioning of Jetfans required – can be determined for each construction project, based on the legal requirements (GarVO).

We recommend the use of an airflow-simulation for large car parks with difficult geometries. It offers maximum planning dependability and is an invaluable tool for assessing the entire system.

Carpark Fans

Ventilation - the Jetfan air outlet system

In normal day-to-day operation, the Jetfans are controlled by the CO system – in accordance with the concentration threshold setting. In this way, carbon monoxide-contaminated air is extracted from the car park. This takes place with either just a few Jetfans operating at a low speed, or with all system components operating at a higher output level, depending on the concentration in the air.

Technical Data (JF050-EC)

- Three Phase 380...480VAC, 50/60Hz input
- Integrated 0.64kW 1.3Amps
- Electronics with inbuilt motor protection (locked motor, over-temp, phase failure)
- Height 375mm
- Weight 84kg
- Thrust: 50N
- Exhaust Area: 67150mm ² (0.06715m ²)
- Density of air at 20°C: 1.2041 kg/m ³
- Velocity: 25.2m/s
- Volumetric Flowrate: 1.7m ³ /s
- Noise Level: 57 dBA@3m

Note: The theoretical velocity and volumetric flowrate produced by jet fan were calculated using thrust rating, the density of air and exhaust area of the jet fan.

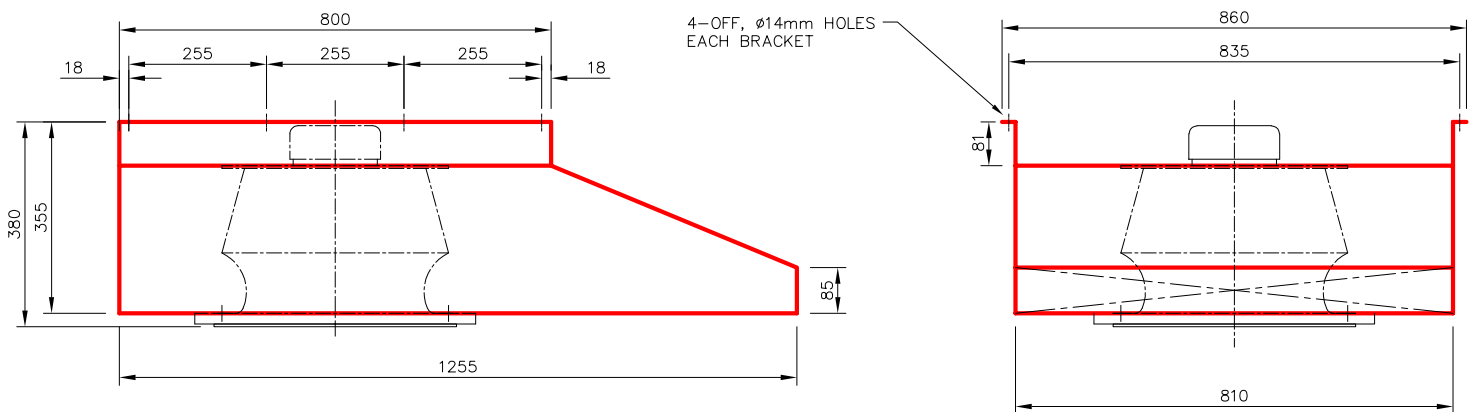

JF050-EC
CENTRIFUGAL JET FAN