

Inline Axial Fans Small Series



MUA - Inline axials
SC - Short case axials

Common Applications

- Sizes from 150 - 630

Features

- Metal construction
- Speed controllable

Order Code

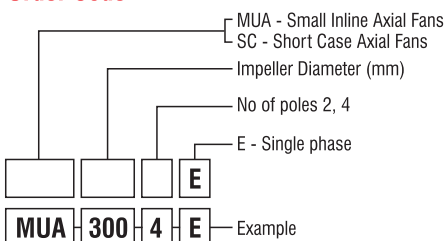

MUA & SC Series

2 Pole

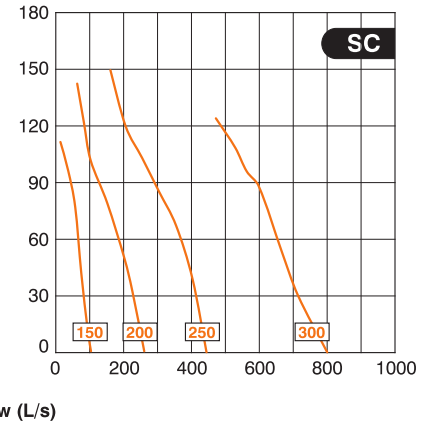
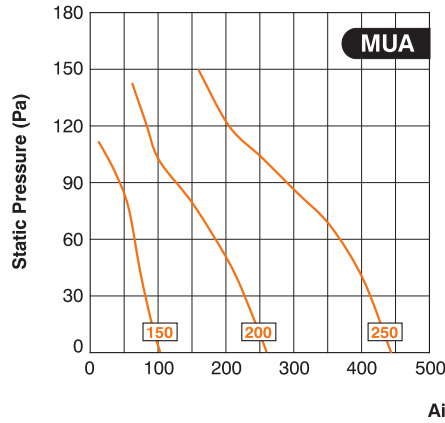

4 Pole

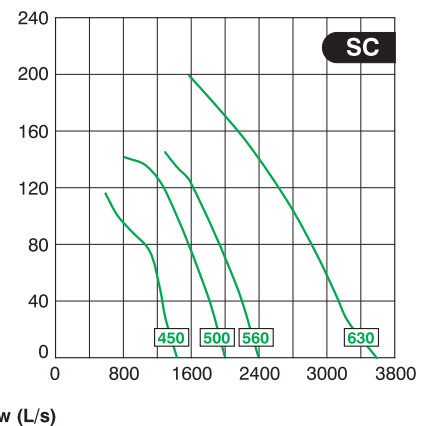
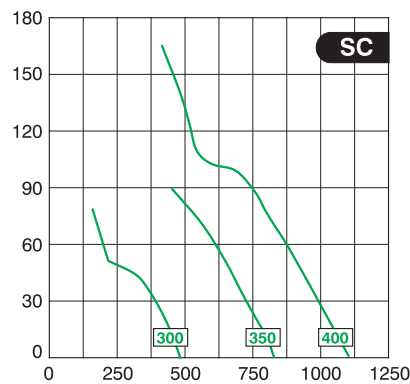
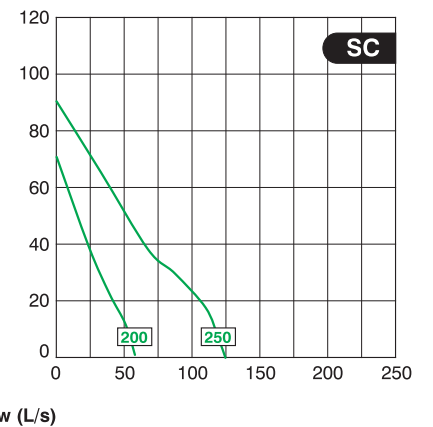
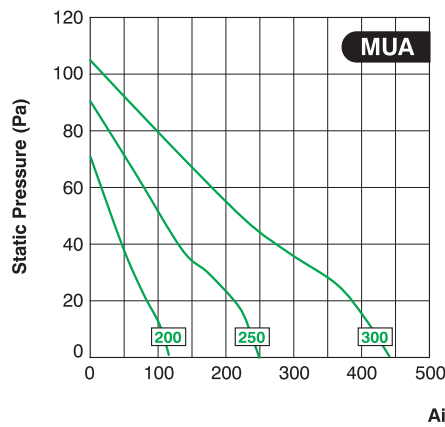

Small Inline Axial Fans

Technical Data ■ 2 POLE ■ 4 POLE

Model	Speed r/s	1 phase		3 phase		Octave Band Frequency Lw db (A)								SPL dB(A) @3m
		KW	Amps	KW	Amps	63	125	250	500	1k	2k	4k	8k	
MUA150/2	43	0.03	0.23	-	-	52	52	60	56	58	59	57	0	45
MUA200/2	43	0.55	0.26	-	-	0	53	60	66	62	60	55	48	48
MUA200/4	23	0.04	0.23	-	-	52	57	57	50	41	42	35	0	40
MUA250/2	42	0.95	0.42	-	-	0	59	69	73	70	64	59	52	55
MUA250/4	24	0.38	0.23	-	-	52	57	57	50	46	42	35	0	40
MUA300/4	23	0.14	0.68	-	-	59	60	60	56	51	47	42	0	44
SC200/2	43	0.06	0.30	-	-	56	57	58	58	57	55	51	47	44
SC200/4	22	0.02	0.07	-	-	39	40	41	41	40	38	34	30	27
SC250/2	42	0.12	0.53	-	-	67	68	69	69	68	66	62	58	55
SC250/4	23	0.06	0.24	-	-	51	52	53	53	52	50	46	42	39
SC300/2	45	0.25	1.10	-	-	70	71	72	72	71	69	65	61	58
SC300/4	23	0.09	0.38	-	-	56	57	58	58	57	55	51	47	44
SC350/4	23	0.14	0.68	-	-	61	62	63	63	62	60	56	52	49
SC400/4	24	0.18	0.81	0.19	0.48	66	67	68	68	67	65	61	57	54
SC450/4	22	0.25	1.15	0.25	0.58	70	71	72	72	71	69	65	61	58
SC500/4	22	0.42	1.85	0.45	0.93	72	73	74	74	73	71	67	63	60
SC560/4	22	-	-	0.65	1.2	83	83	77	76	78	77	72	63	62
SC630/4	22	-	-	0.86	1.95	76	88	80	82	83	83	78	70	67

Note: Amperages shown are a guide only.

Technical Data

Model	Kg	A	B	C	D	E
MUA150	2	-	-	157	-	148
MUA200	4	80	90	300	55	200
MUA250	5	80	90	300	55	251
MUA300	5	80	90	300	55	300

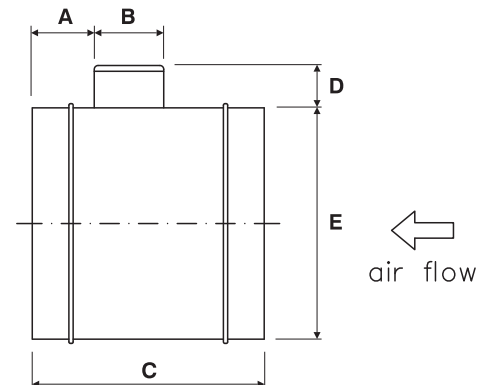

Technical Data

Model	Kg	A	B	C	D
SC200	3	200	255	6	85
SC250	4	250	306	6	95
SC300	5	300	382	6	180
SC350	6	350	421	6	180
SC400	8	400	466	6	190
SC450	10	450	515	6	190
SC500	19	500	567	6	250
SC560	25	560	630	6	250
SC630	45	630	710	6	250

